

Technical  
Drawing

Desenho  
Técnico

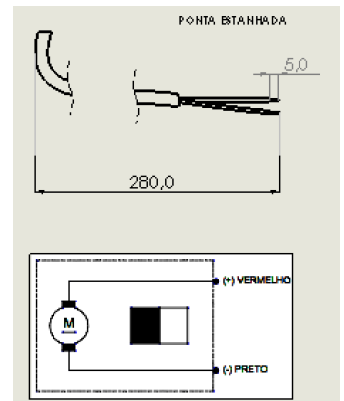
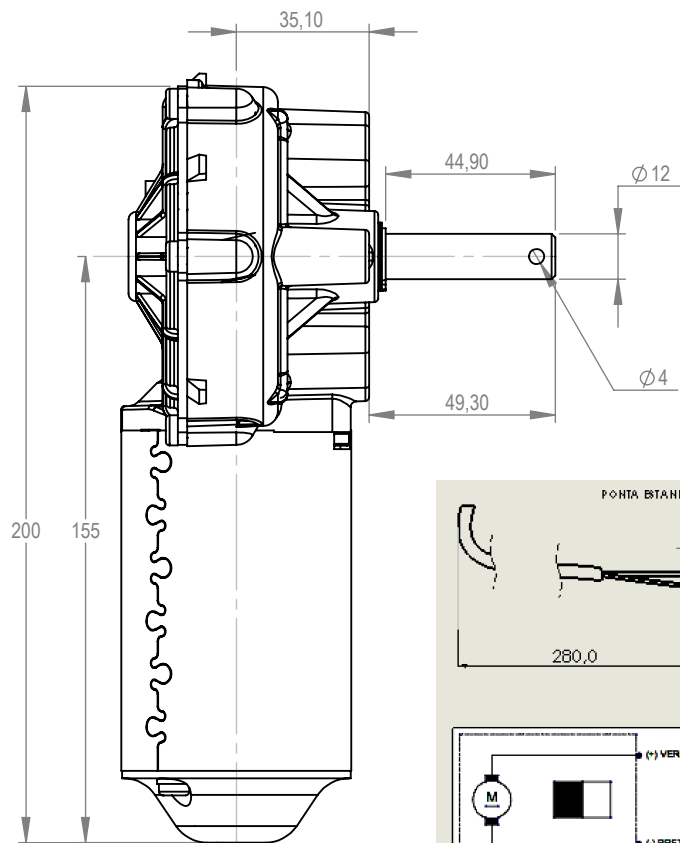
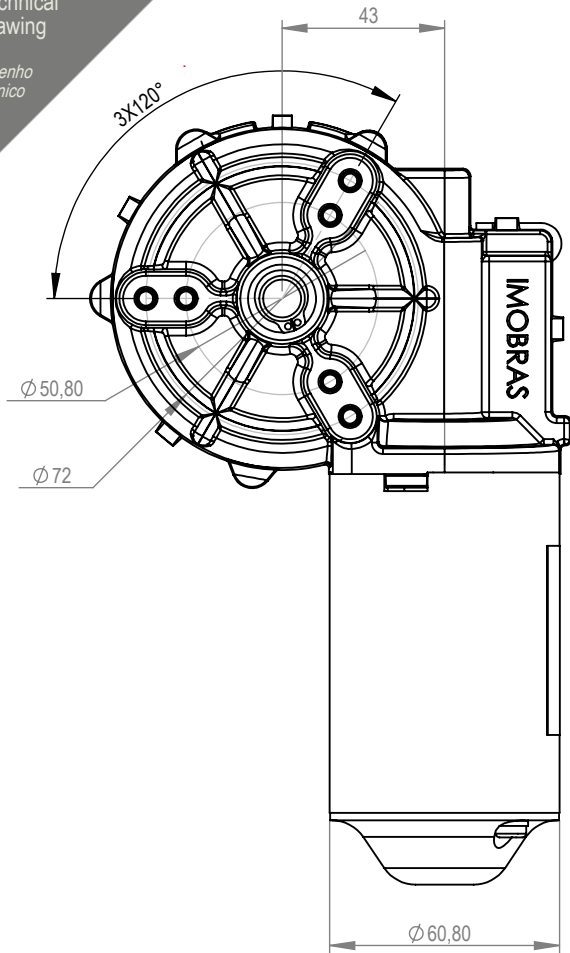

Technical  
Specification

Especificação  
Técnica

Imagem  
Ilustrativa

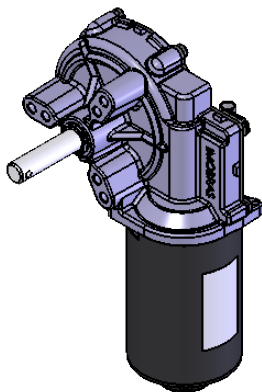

100502512

CARACTERÍSTICAS ELÉTRICAS	
U <sub>N</sub> (V)	13
P <sub>N</sub> (W)	51
n <sub>N</sub> (rpm)	82
I <sub>N</sub> (A)	5
I <sub>max</sub> (A)	58
M <sub>N</sub> (Nm)	6
M <sub>max</sub> (Nm)	35
i	55:1
Rotação	L / R
Peso (Kg)	1,300

